



LASKOMEX®



Video door phone set
Bastion Draco II

1. Safety of operation and maintenance	3
2. Purpose and characteristic of video door phone	3
3. Elements of Draco II video door phone	3
- MVC-6601 monitor	3
- External panel BVC-6601	4
- KSAD 1500120W1EU or GP005E-150-100 power adapted	4
- Electro-catch	4
- Feeder to electro-catch	4
4. Before the assembly	4
- Specify the places where video door phone elements are to be mounted	4
- Electric installation of video door phone	5
5. Installing and connecting the video doorphone components	5
- Installing and connecting the MVC-6601 monitor	5
- Installing and connecting the additional monitor	6
- Installing and connecting the BVC-6601 outdoor panel	6
- Installing and connecting the power adapter	6
- Installing and connecting the power adapter	6
6. Video doorphone operation	8
7. Video Doorphone maintenance	7
7. Connecting diagrams	8
9. Technical data	10

1. Safety of operation and maintenance

- Before installing and using the video door phone, read the assembly and operating manual.
- Electrical installation should be made in accordance with PN-IEC 60364-1 standard by an authorized person.
- Electrical installation should be made in such a way as to prevent exposure to direct lightning discharge.
- Video door phone elements should be used as intended. Using video door phone elements for other purposes, including with equipment other than specified in the manual or connecting them in other manner than prescribed by the manufacturer may lead to their damage, fire or electric shock.
- Do not cover the openings in the monitor housings.
- Do not insert any metal items in the openings in the monitor housing and the feeder as it may lead to electric shock or fire.
- The external panel should be installed in a place with low noise level.
- Video door phone elements should be connected to an electrical installation when the feeder is disconnected from the power network.

2. Purpose and characteristic of video door phone

- Video door phone Bastion Draco II is designed for single family houses, companies, institutions and service providers.
- Four monitors may be connected to the external panel.
- Two external panels can be connected to the one monitor
- The video doorphone is a hands-free and headphone device featuring a colour display. The half-duplex voice communication requires no manual channel switching: the direction is switched by voice.
- The external panel is mounted on the wall.
- The panel is equipped with a colour camera and a LED display facilitating viewing visitors' faces at night.

3. Elements of Draco II video door phone

MVC-6601 monitor

This is a hands-free (loudspeaking) monitor with a 7" colour display with brightness, saturation and volume adjustment, and buttons for receiving calls, forwarding the calls to others monitor (optional), turning on the camera view and triggering the door release.

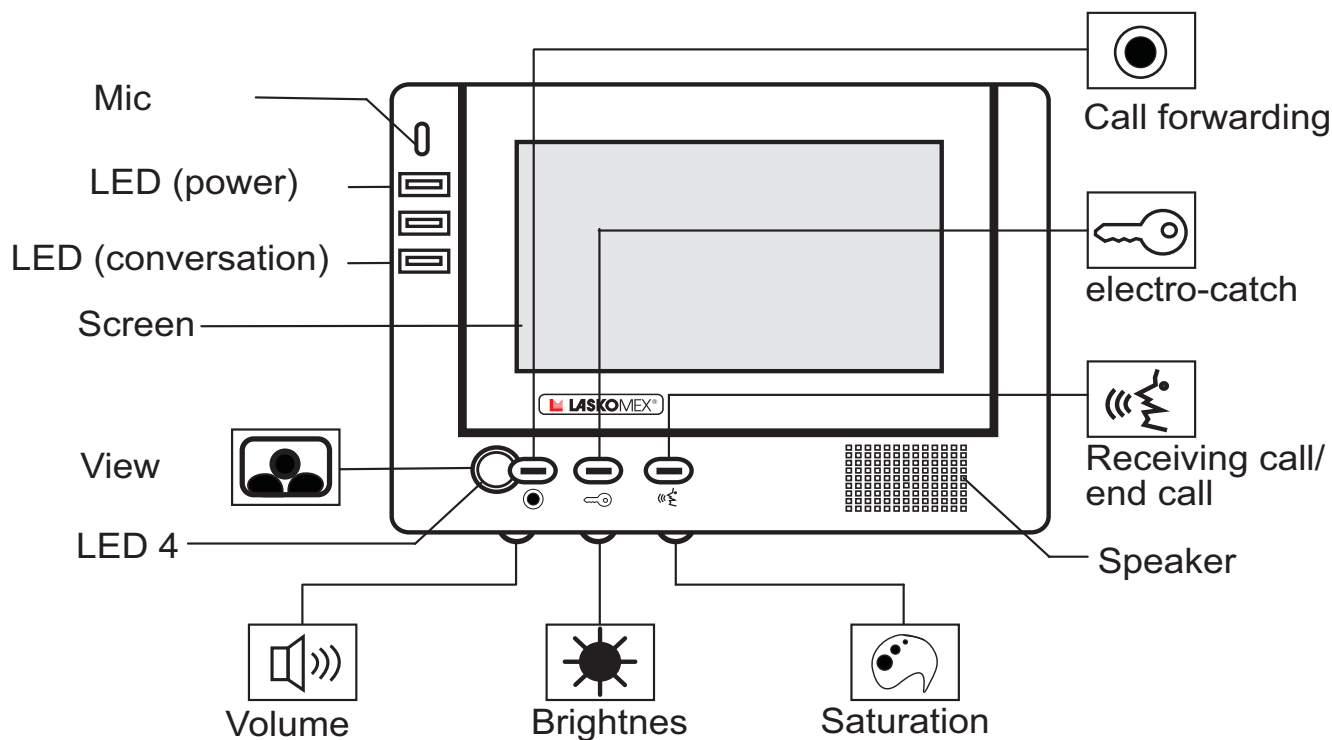

Fig 1. MVC-6601 video monitor

External panel BVC-6601

A vandal-proof panel with a colour camera, camera illuminator, speaker, microphone and calling button. The panel is mounted on the wall and equipped with a door strike relay activated on pressing the monitor button

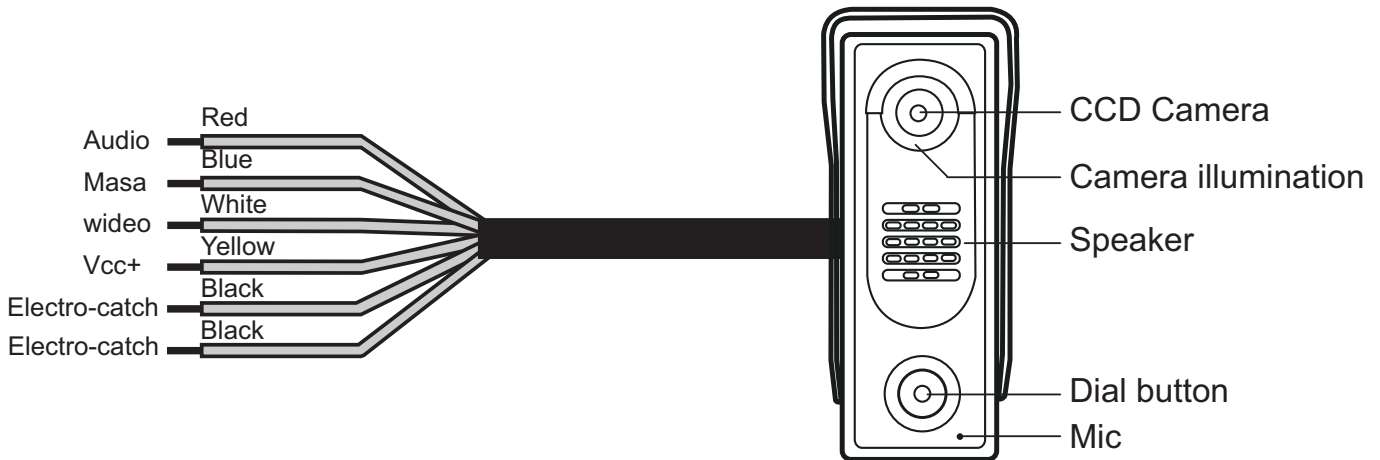

Fig 2. External panel BVC-6601

KSAD 1500120W1EU or GP005E-150-100 power adapted

A 15V DC/1.2A or 15V DC/1A power adapter with IP40 protection grade. It supplies power to the monitor and indirectly powers the outdoor panel.

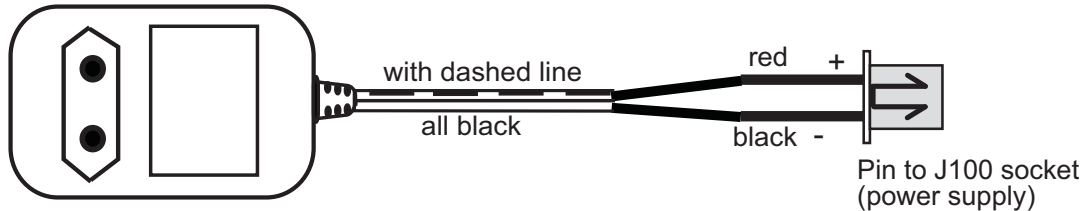

Fig 3. KSAD 1500120W1EU or GP005E-150-100

The package also includes:

- monitor holding bracket
- mounting screws
- wires with connectors necessary to connect the kit

Additional components **not included** in the basic kit:

Electro-catch

Electro-catch of 12V AC/1A max. should be used in the video door phone. While selecting the electro-catch, take into account the mechanical build and type (left or right) of the door or gate to be blocked. Electro-catch of Openers&Closers company may be used (technical details at: www.laskomex.com.pl).

Feeder to electro-catch

ACV feeder: 12V AC/800 mA to mount on a DIN rail. Used to power to electro-catch.

4. Before the assembly

Specify the places where video door phone elements are to be mounted.

- Mount the monitor in a place not exposed to strong light (e.g. close to the lamp, window etc.) as it may obstruct viewing image on the screen.

- Do not mount the monitor in place where it could be exposed to humidity e.g. in bathrooms.
- Do not mount the monitor near the sources of strong electromagnetic interference (wiring, TV sets etc.)
- Do not mount the monitor in heating sources - stoves, radiators etc.
- The external panel should be mounted in such a place that the camera lens is not directed to light source (sun, strong lamp post) because it will significantly obstruct or prevent viewing the visitors' faces.
- The image on the screen depends on the height the panel is mounted at. The recommended height is ca. 150 cm. Such height allows for viewing the face of an adult of average height standing ca. 50 cm from the panel. The assembly height should be determined on a trial basis.
- Do not mount the external panel at the distance exceeding 100 m from monitor (with the appropriate cable sections).
- Mount the feeder inside, in a place not exposed to humidity.
- The above recommendations relate to both the monitor feeder and door strike feeder. The door strike feeder may be mounted near the external panel (e.g. in the installation box of fence pillar).

Electric installation of video door phone.

Elements of video door phone may be connected with any cable with section meeting the requirements specified in Table 1.

Coaxial cable 75Ω should be used to transmit video signal. The coaxial cable should be connected as presented in Figure 7.

The maximum distance between the external panel and the monitor should not exceed 100 m.

To put down in the ground and outside the room it is necessary to use the damp-proof cables. The number of wires in the cables is shown on the single line diagram (fig. 4).

NOTE: It is necessary to pay special attention on quality of connection`s wires and also on proper isolation of every connection especially when weather conditions appears. It is recommended to use hermetic cable box and shrink wrap in the place of joint the wires. Maladjustment to those recommendation may lead to the impropiety activity of the door phone set.

Connection		Distance		
		<20m	<50m	<100m
outdoor station - monitor	+Vcc,masa,audio	0,2mm ²	0,44mm ²	0,75mm ²
	video	Coaxial cable		
monitor - monitor	+Vcc,masa,audio	0,2mm ²	————	
	video	Coaxial cable	————	
power adapter - outdoor station, power adapter - monitor		1mm ²	1.5mm ²	————
Power adapter - 230V		maximum 4m,		1mm ²

Table 1. Minimum cable section according to the distance between door phone elements

5. Installing and connecting the video doorphone components

Installing and connecting the MVC-6601 monitor

For easier installation, all the wires of the video doorphone can be run to a standard cable box installed in the wall. Once mounted, the monitor should cover the whole box. This will make it easier to install and mount the monitor.

- The monitor is mounted on a metal holding bracket fixed to the wall. To fix the bracket, place it against the wall in the intended place of installation and mark holes for rawl plugs.
- Drill the holes as market and fix the bracket to the wall using rawl plugs.

- Connect the wires to the J102 socket connector provided with the kit, as shown in the diagram, by soldering them to the wiring system. Protect all soldered connections and isolated portions of the wires against short-circuit with a shrinking sleeve or insulating tape. Plug the connectors to the sockets.
- Mount the monitor on the holding bracket.

Installing and connecting the additional monitor (max 4)

For connecting two or more MVC6601 monitors (max 4) to a single outdoor panel, run a separate power supply (J100 socket) to the additional monitor and connect the two monitors. See Figure 8, 9 and 10. Set jumper JP2 in the last most remote monitor from external panel. JP2 - Matching the impedance to the coaxial cable.

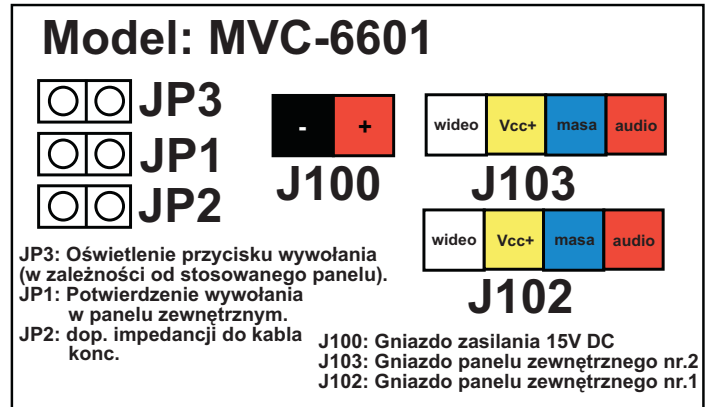
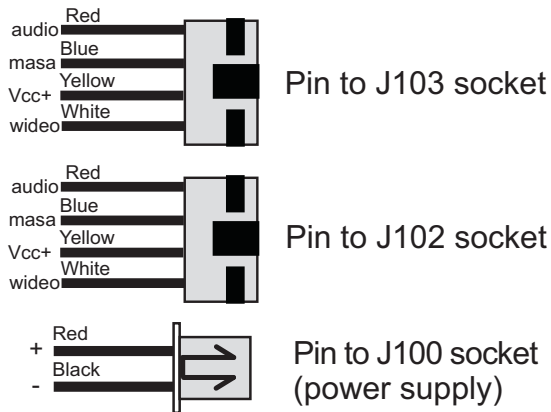

fig 4. Sticker on the back of the monitor and plugin added to kit to connecting monitor

Installing and connecting the BVC-6601 outdoor panel.

- Unscrew the screw holding the panel to the hood.
- Place the hood at the intended place of installation, mark holes for the rawl plugs and drill the holes (Fig. 5b). The camera lens should be placed at a height of approx. 150 cm (see Fig 5a).
- Pull the wiring system cable through the circular hole in the casing and fasten the casing to the wall (Fig. 5c).
- Connect the wires according the diagram (see Fig. 6, 7, 8 and 9). As shown in Fig. 5, the wires should be connected to the outdoor panel with snap-on connectors (see Fig. 4). Place the panel against the hood and secure it with the mounting screw (Fig. 5D).

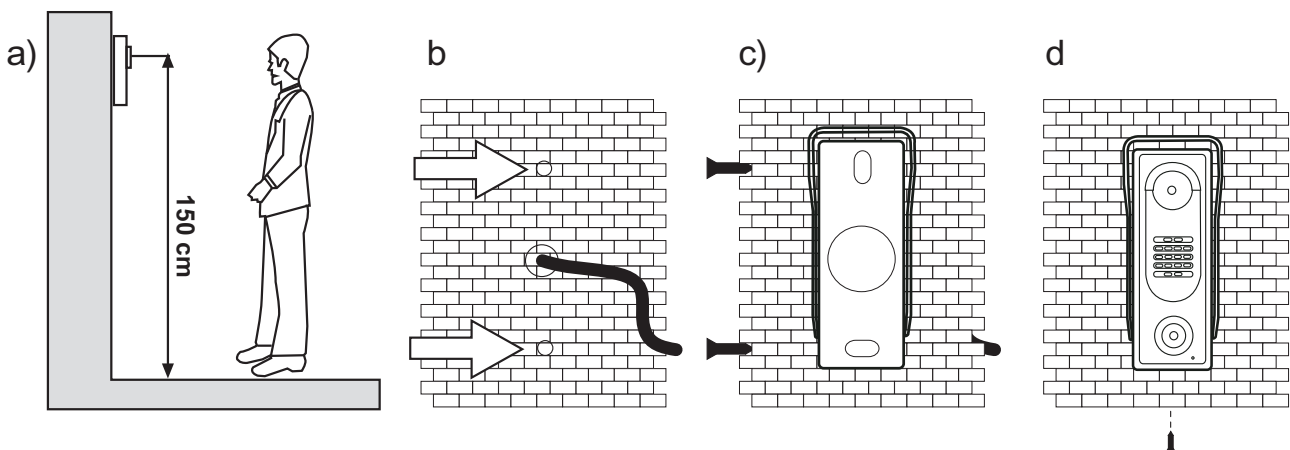

fig 5. Outdoor panel instalation

Installing and connecting the power adapter

The wire marked with a grey dotted line is plus, and the solid black one is minus – see Fig. 3. The wires should be connected according to the connection diagram.

Installing and connecting the door release

The door release is controlled by the relay in the outdoor panel and must be powered from a separate DC power adapter.

Install the door release in the gate or the entrance door according to the manufacturer's recommendations. Then proceed to connect the wires in the outdoor panel (two black wires), power adapter wires and the door release, as shown in the connection diagram (see Figures 6, 7, 8 and 9).

6. Video doorphone operation

- Pressing the calling button on the outdoor panel triggers a calling signal in the monitor and switches on the camera view (if the additional monitor has been installed, the camera view will display on both monitors).

- To switch on voice communication, press the button  (talk, see Fig. 1). In two-monitor installations, if voice communication has been established by one of the monitors, the other one will switch off after approx. 1 minute.

- If voice communication is not activated after the calling, the monitor will automatically switch off after approx. 1 minute.

- **The talk time is limited to approx. 120 seconds, after which the phone will automatically hang up.**

- To hang up, press the button  (talk) again.

- The door release can be activated at any time during the conversation by pressing the button  on the monitor. The release continues while the button remains pressed.

- The camera view on the monitor can be switched on at any moment by pressing the button  (view). Pressing the button again will switch the view to the next entrance, and pressing the button yet again will switch off the camera view.

- sequential operation. To activate voice communication in the camera view mode, press the button  (talk).

- To accept a redirected call, press the button  (talk).

- The MVC-6601 monitor features controls for volume, brightness and colour saturation adjustment (see Fig. 1).

7. Video Doorphone maintenance

Components of the video doorphone should be cleaned with a wet cloth or with cleaning agents designed for plastics.

ATTENTION!

Do not use solvents or abrasive cleaners, as they can result in permanent damage to the surface of the casing! Avoid any contact of doorphone components with water or cleaning agents, as this might result in damaging the device and electric shock!

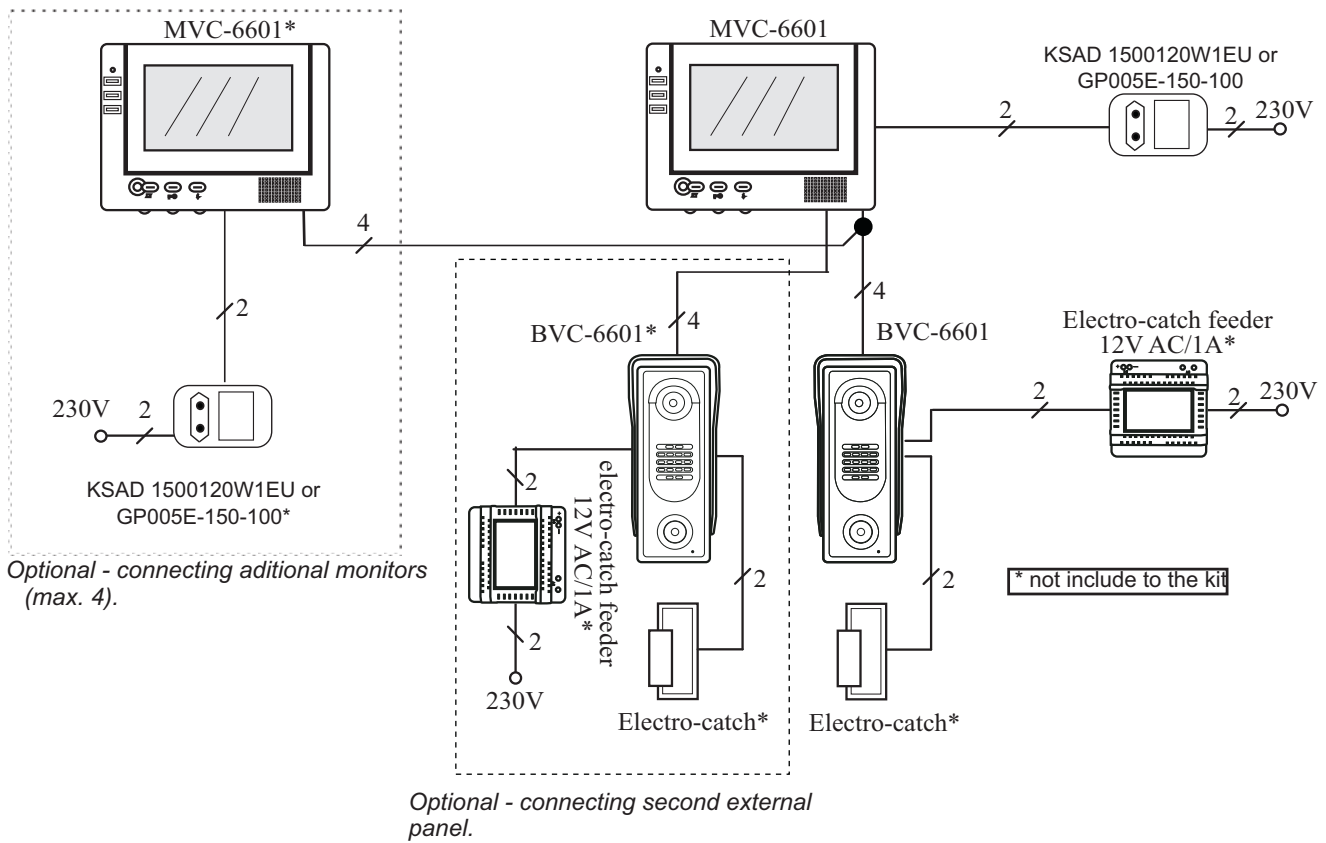

Figure 6. Connection of Draco II video door phone - single line diagram.

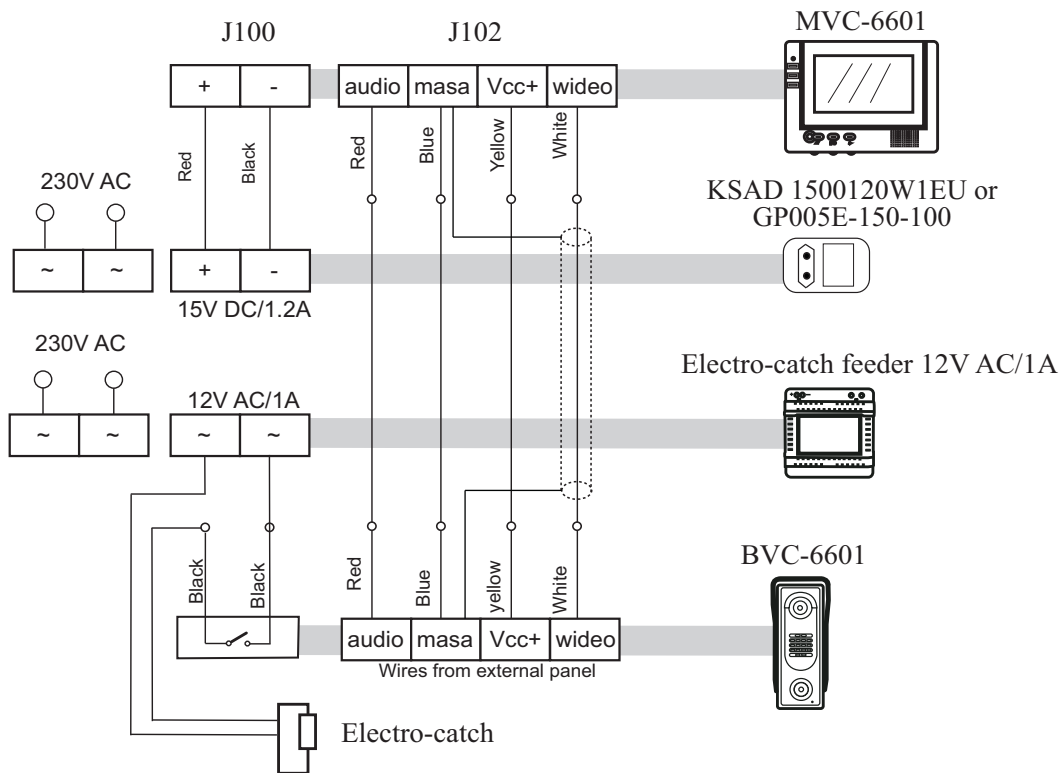

Figure 7. Block diagram of connecting elements of Draco II video door phone

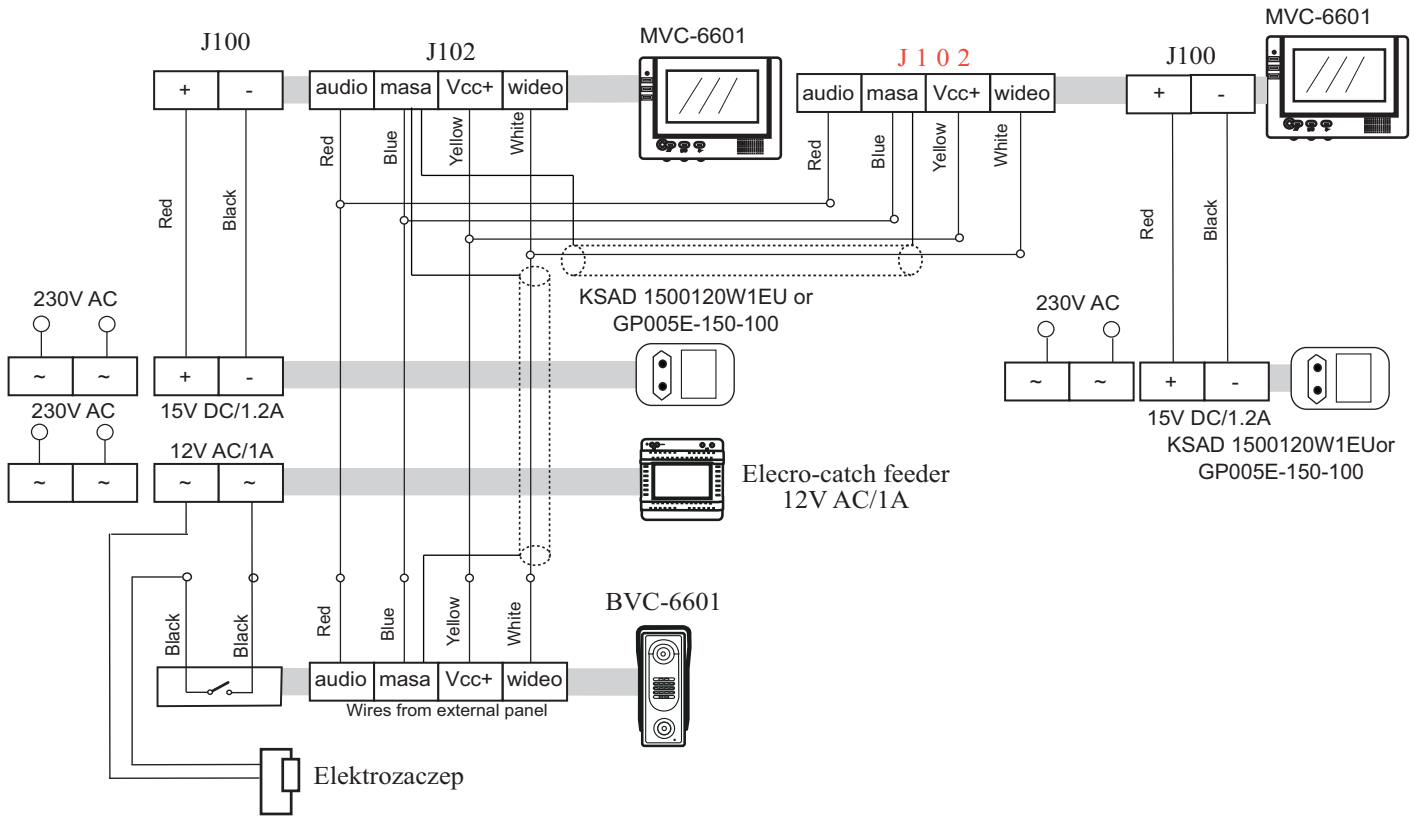

Figure 8. Block diagram of connecting elements of Draco II video door phone with additional monitor

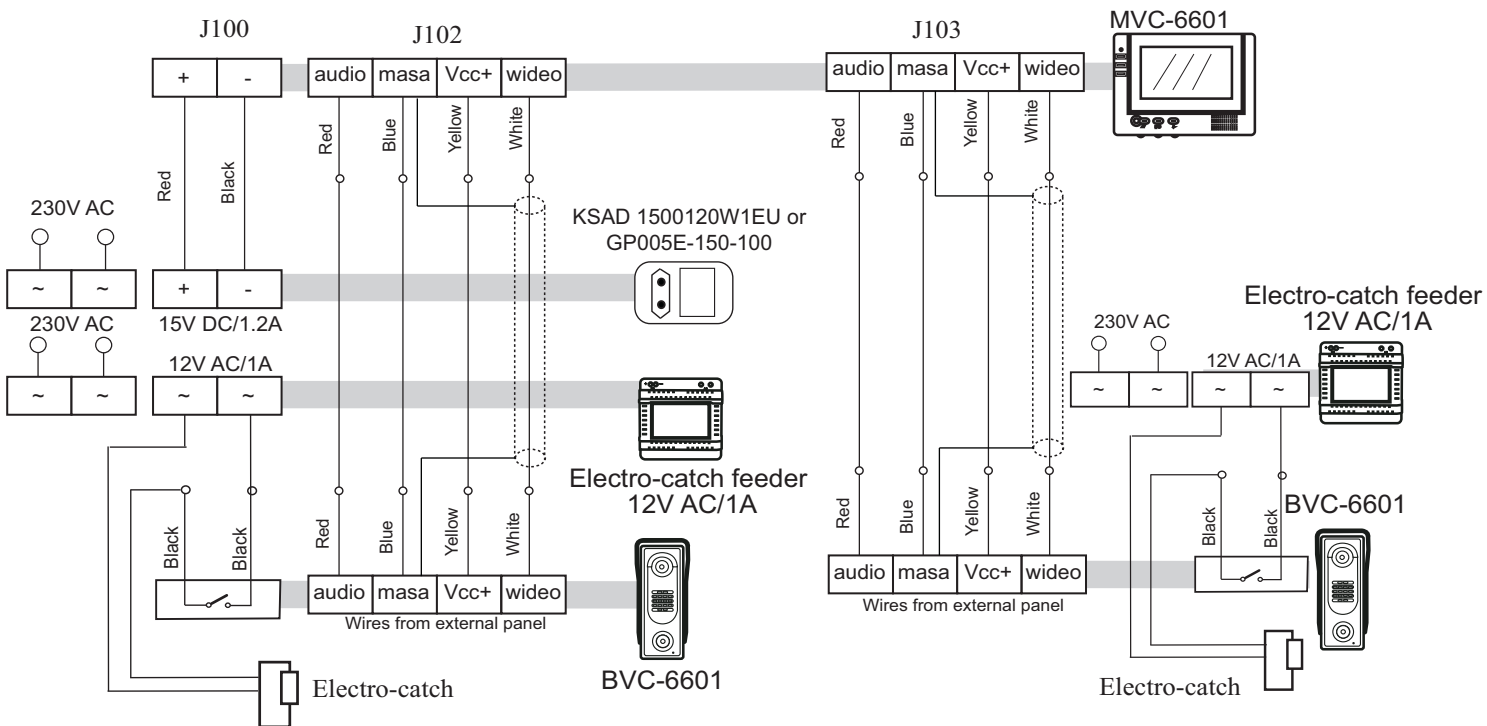

Figure 9. Block diagram of connecting elements of Draco II video door phone with additional external panel

9. Technical data

Monitor MV-6601

Screen size	7"
Dimension	240x175x35
Supply voltage	15V DC/0.8A
Operation temperature	0°C...70°C

BVC-6601 external panel

Dimension	135x55x40
Operation temperature	-20°C...70°C
Angle of view	60° horizontally

Power supply

	KSAD 1500120W1EU	or	GP005E-150-100
Input voltage	230V AC		230V AC
Output voltage	15V DC/1,2A max.		15V/1A
Dimension	81x43x67		81x43x67
Operation temperature	0°C...40°C		0°C...40°C
Degree of protection	IP40		IP40

INSTRUCTION ON ENVIRONMENT PROTECTION

This product was marked with a symbol of crossed dustbin according to European Directive 2002/96/WE on used electric and electronic equipment. Used equipment cannot be placed with other wastes from households. Product user is obliged to give it to the firm which collects used electronic or electric equipment such as local collection points, shops, places appointed by the producer or commune waste collection units.

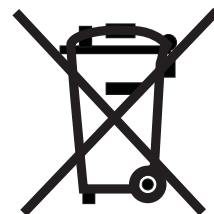

List of collecting units of used Laskomex equipment is available on www.laskomex.com.pl website or telephone No. 42 671 88 68.

Product packing should be removed according to environment protection regulations.

Remember!

Selective collection and recycling of used electronic and electric equipment considerably contributes to the protection of human health and life as well as protection of natural environment.

Return of packaging materials for the material recycling saves raw materials and reduces generating of wastes.